

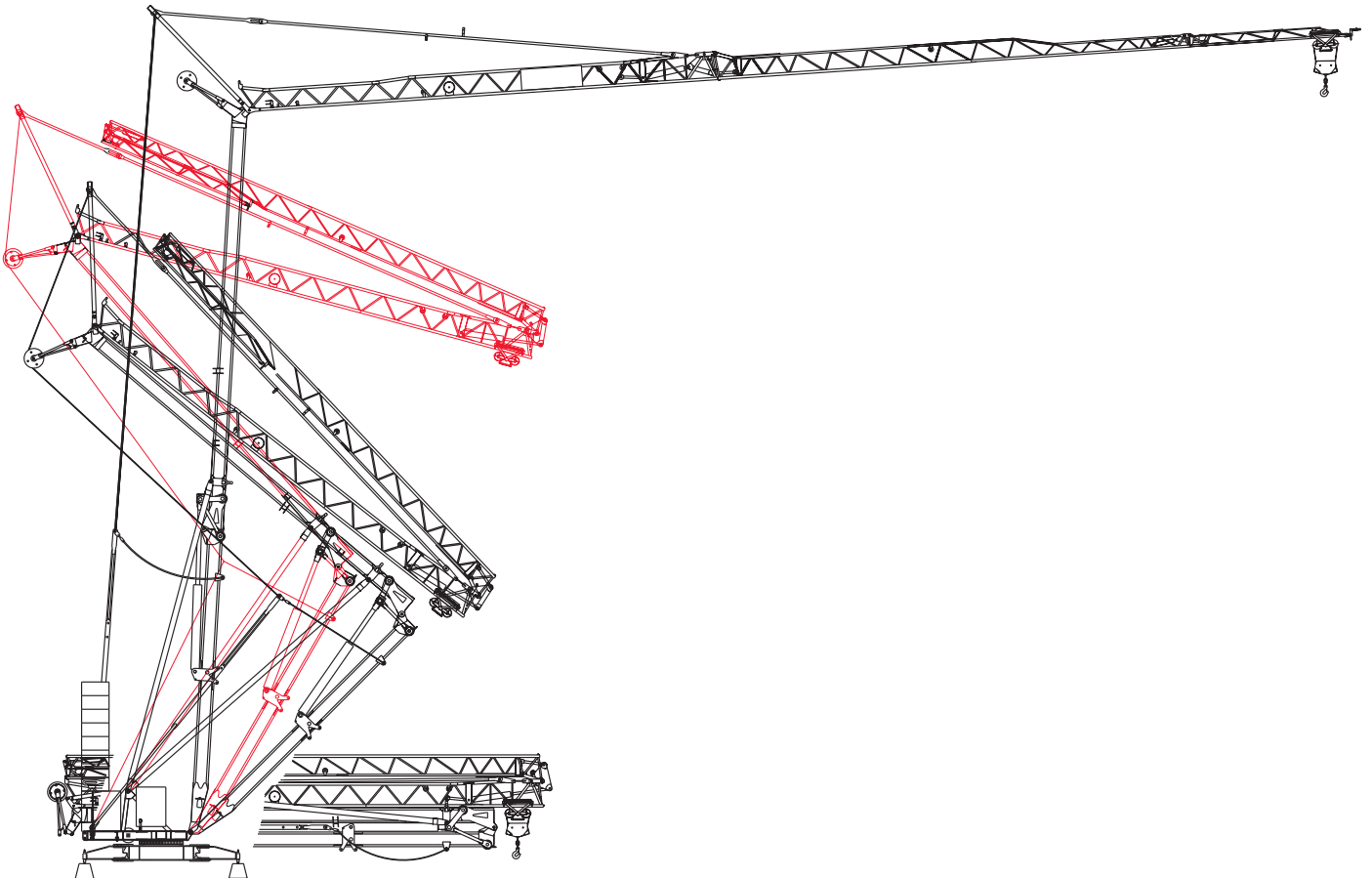

HR 32

Building tower cranes since 1946



CARLO RAIMONDI Carlo Raimondi fu Rodolfo S.p.A.
C.so Garibaldi, 253 - 20025 Legnano (MI)
Telefono 0039.0331.548061 Fax 0039.0331.450400
<http://www.raimondigr.com>



A4 FEM1.001

I

SCHEDA TECNICA

GRU AUTOMONTANTI
IDRAULICHE

GB

TECHNICAL DATA SHEET

SELF ERECTING
CRANES

F

FICHE TECHNIQUE

GRUES MONTAGE
RAPIDE

D

TECHNISCHE INFOKARTE

SELBSTMONTIERENDE
HYDRAULIKKRÄNE

RUS

ТЕХНИЧЕСКИЕ
ХАРАКТЕРИСТИКИ

КРАНЫ ГИДРАВЛИЧЕСКИЕ
САМОМОНТИРУЮЩИЕСЯ



Courtesy of Crane.Market

CONFIGURAZIONE - REAZIONI - HR32

CONFIGURATION - REACTIONS / CONFIGURATION - RÉACTIONS / KONFIGURAZION – REAKTIONEN / КОНФИГУРАЦИЯ КРАНА

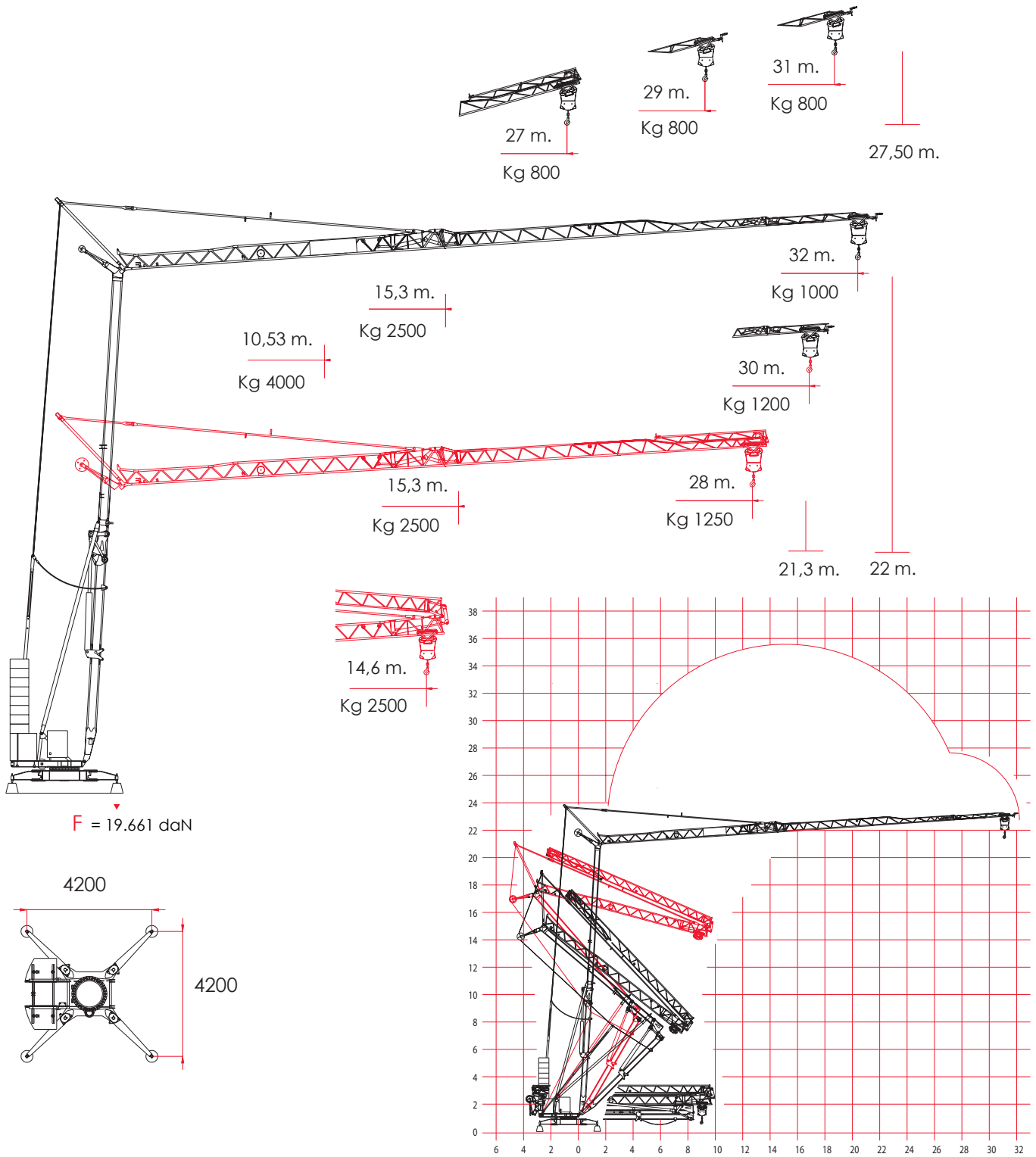

I

F [daN]

SFORZI MASSIMI
AL PIEDE

GB

F [daN]

MAX STRESSES AT
THE FOOT

F

F [daN]

EFFORTS MAX.
AU PIED

D

F [daN]

MAX. BEANSPRUCHUNG
AM FUSS

RUS

F [daN]

МАКС. УСИЛИЯ НА
ПОДНОЖИЕ

CARATTERISTICHE AZIONAMENTI PRINCIPALI

MAIN DRIVE CHARACTERISTICS / CARACTÉRISTIQUES ACTIONNEMENTS PRINCIPAUX / HAUPTBEDIENUNGSEIGENSCHAFTEN / ХАРАКТЕРИСТИКА ГЛАВНЫХ ПРИВОДОВ



VELOCITÀ / VITESSE / SPEED / GESCHWINDIGKEIT / СКОРОСТЬ
 REAZIONI / RÉACTIONS / REACTIONS / REAKTIONEN / РЕАКЦИИ



TRIFASE 380V 50 Hz 15 kW



m/l'	5,10	20,50	41,00
kg	2.500	2.500	1.000
kW			



m/l'	2,50	10,00	20,50
kg	4.000	4.000	1.000
kW			



g/l'	9,00*	30,00	48,00
kW		* [con Inverter]	



m/l'	0,30	0,60	0,90
kW			

R = 2,2 m

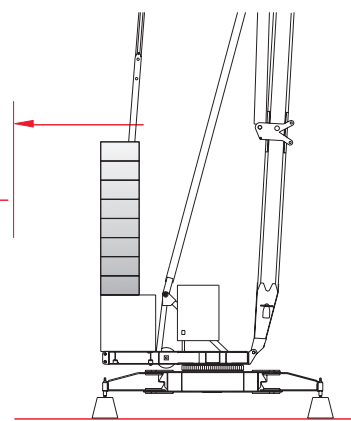

F = 19.661 daN

28 m

(IV) 1.200 Kg / (II) 1.250 Kg

m ▶	10,86	15,79	16,20	17,20	18,20	19,20	20,20	21,20	22,20	23,20	24,20	25,20	26,20	27,20	28,00
-----	-------	-------	-------	-------	-------	-------	-------	-------	-------	-------	-------	-------	-------	-------	-------

(IV) Kg	4.000	2.467	2.371	2.197	2.045	1.911	1.792	1.686	1.590	1.504	1.426	1.354	1.289	1.228	1.200
(II) Kg	-	0.250	2.421	2.247	2.095	1.961	1.842	1.736	1.640	1.554	1.476	1.404	1.339	1.278	1.250

30 m

(IV) 1.150 Kg / (II) 1.200 Kg

m ▶	11,30	16,49	17,00	18,00	19,00	20,00	21,00	22,00	23,00	24,00	25,00	26,00	27,00	28,00	29,00	30,00
-----	-------	-------	-------	-------	-------	-------	-------	-------	-------	-------	-------	-------	-------	-------	-------	-------

(IV) Kg	4.000	2.447	2.357	2.193	2.048	1.920	1.806	1.703	1.611	1.526	1.450	1.380	1.315	1.256	1.201	1.150
(II) Kg	-	2.500	2.407	2.243	2.098	1.970	1.856	1.753	1.661	1.576	1.500	1.430	1.365	1.306	1.251	1.200

32 m

(IV) 0.950 Kg / (II) 1.000 Kg

m ▶	10,53	15,28	16,00	17,00	18,00	19,00	20,00	21,00	22,00	23,00	24,00	25,00	26,00	27,00	28,00	29,00	30,00	31,00	32,00
-----	-------	-------	-------	-------	-------	-------	-------	-------	-------	-------	-------	-------	-------	-------	-------	-------	-------	-------	-------

(IV) Kg	4.000	2.500	2.309	2.137	1.987	1.855	1.738	1.633	1.539	1.455	1.378	1.308	1.244	1.185	1.130	1.080	1.034	0.990	0.950
(II) Kg	-	2.500	2.359	2.187	2.037	1.905	1.788	1.683	1.589	1.505	1.428	1.358	1.294	1.235	1.180	1.130	1.084	1.040	1.000

I

R [m]

RAGGIO DI ROTAZIONE

GB

SPIN BEAM

F

RAYON DEROTATION

D

UMDREHUNGSRADIUS

RUS

РАДИУС ВРАЩЕНИЯ

F [daN]

SFORZI

STRESSES

EFFORTS

KRÄFTE

УСИЛИЯ

SOLUZIONE DI TRAINO

TRACK LOAD PLAN / PLAN DE CHARGEMENT / SCHLEPPLÖSUNG / ВАРИАНТ БУКСИРОВКИ

13.520 m

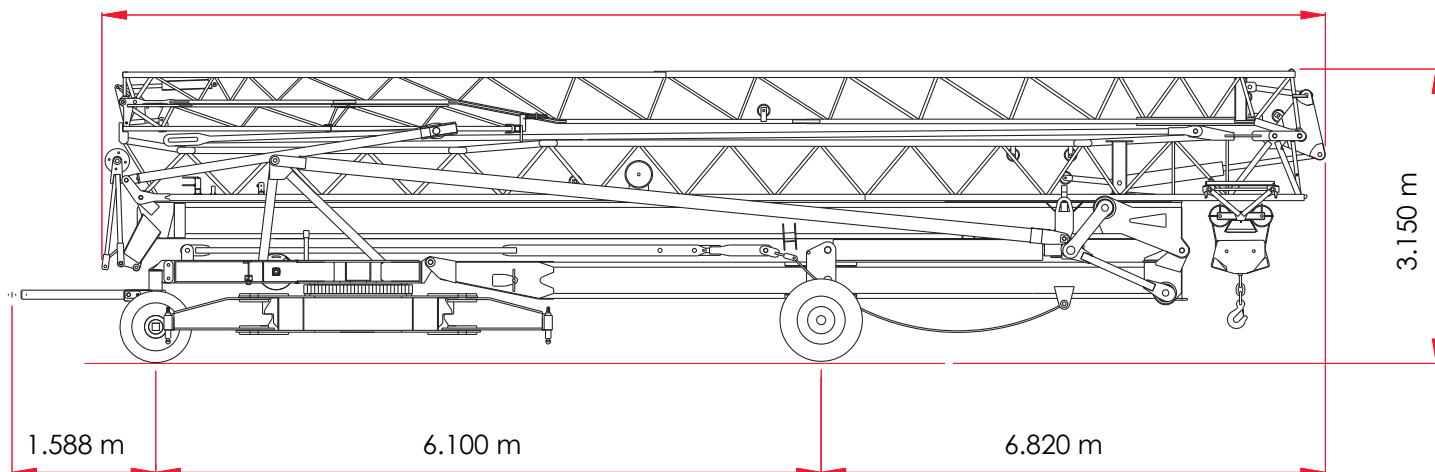
**I**PESO DELLA GRU SENZA
ASSALI: 10.345 Kg**GB**DEAD WEIGHT WITHOUT
TRANSPORT AXALES
10.345 Kg**F**POIDS DE LA GRUE SANS
ESSIEUX 10.345 Kg**D**GEWICHT DES KRANS
OHNE ACHSEN 10.345 Kg**RUS**БЕС КРАНА БЕЗ
МОСТОВ, 10.345 КГPESO ZAVORRA ROTANTE:
20.800 KgROTATING BALLAST
WEIGHT 20.800 KgPOIDS LEST PIVOTANT
20.800 KgGEWICHT DES DREHBAL-
LASTS 20.800 KgБЕС ВРАЩАЮЩЕГОСЯ
БАЛЛАСТА, 20.800 КГ

DISTRIBUTORE / DEALER / DISTRIBUTEUR / VERTEILER / ДИЛЕР

**CARLO RAIMONDI S.p.A.**CORSO GARIBALDI n° 253
20025 LEGNANO [MI] - ITALY@ www.raimondigru.it

INFO



0039.0331.548061



0039.0331.450400



PROJECT



0039.0331.548061

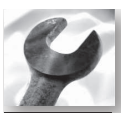

S.A.T.



0039.0331.548061.258

DIN EN ISO 9001:2000
Zertifikat n° 15 100 85248