

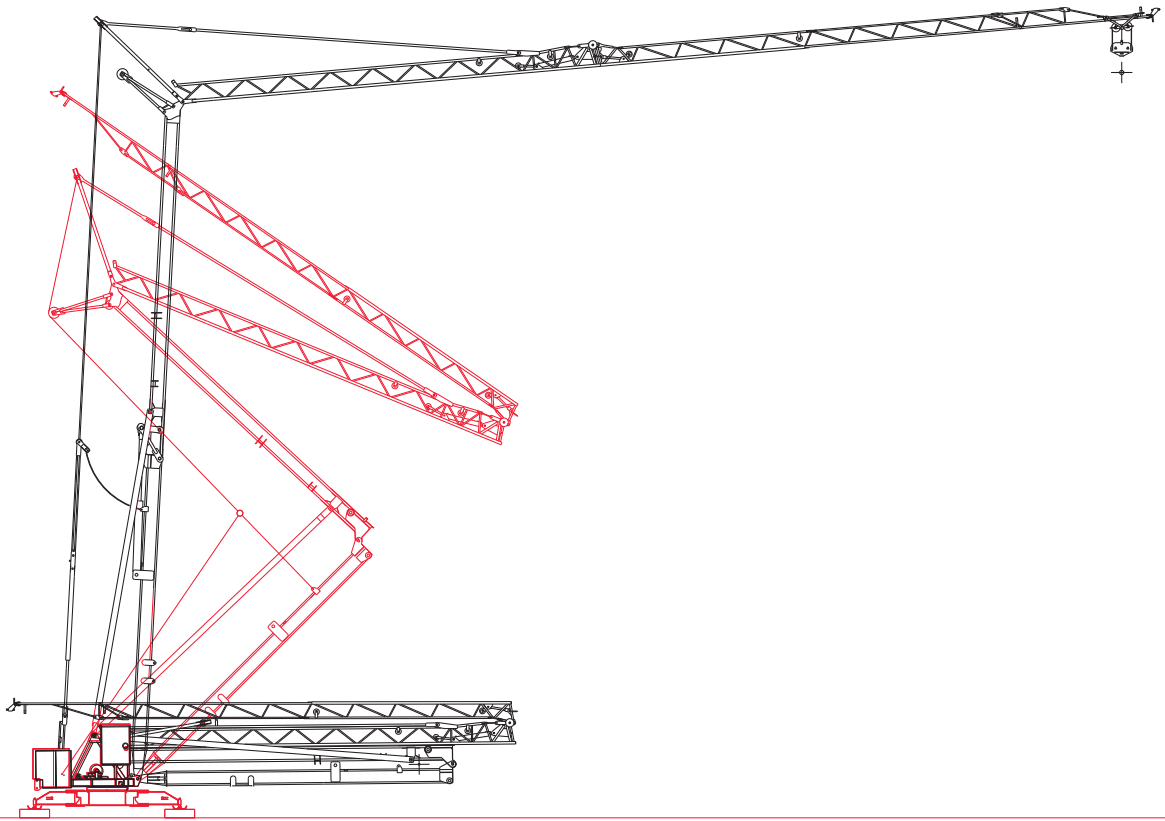

HR 24

Building tower cranes since 1946



CARLO RAIMONDI Carlo Raimondi fu Rodolfo S.p.A.
C.so Garibaldi, 253 - 20025 Legnano (MI)
Telefono 0039.0331.548061 Fax 0039.0331.450400
<http://www.raimondigr.com>



A4 FEM1.001

I

SCHEDA TECNICA

GRU AUTOMONTANTI
IDRAULICHE

GB

TECHNICAL DATA SHEET

SELF ERECTING
CRANES

F

FICHE TECHNIQUE

GRUES MONTAGE
RAPIDE

D

TECHNISCHE INFOKARTE

SELBSTMONTIERENDE
HYDRAULIKKRÄNE

RUS

ТЕХНИЧЕСКИЕ
ХАРАКТЕРИСТИКИ

КРАНЫ ГИДРАВЛИЧЕСКИЕ
САМОМОНТИРУЮЩИЕСЯ



Courtesy of Crane.Market

CONFIGURAZIONE - REAZIONI - HR24

CONFIGURATION - REACTIONS / CONFIGURATION - RÉACTIONS / KONFIGURAZION – REAKTIONEN / КОНФИГУРАЦИЯ КРАНА

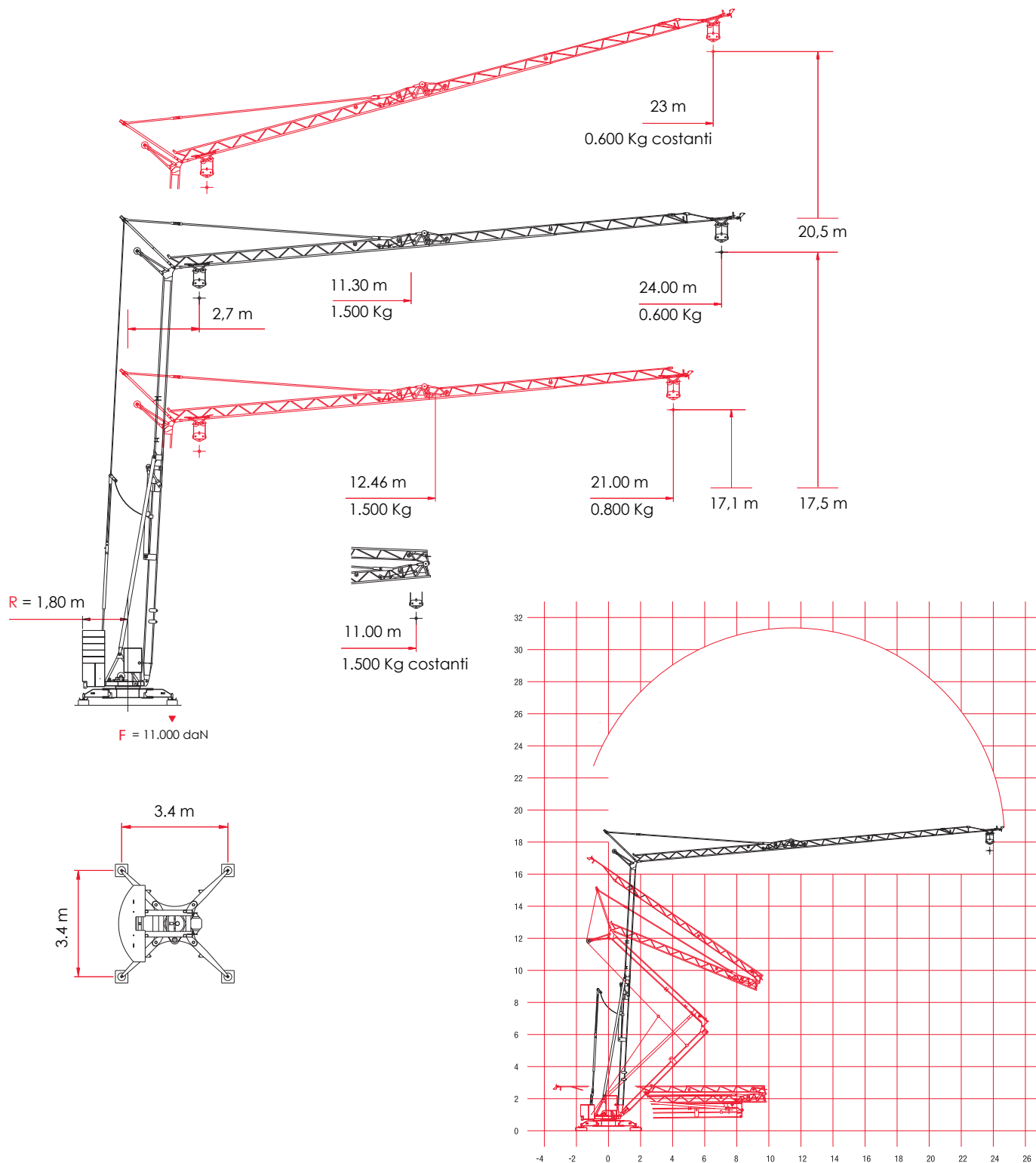

I	GB	F	D	RUS
F [daN]	F [daN]	F [daN]	F [daN]	F [daN]
SFORZI MASSIMI AL PIEDE	MAX STRESSES AT THE FOOT	EFFORTS MAX. AU PIED	MAX. BEANSPRUCHUNG AM FUSS	МАКС. УСИЛИЯ НА ПОДНОЖИЕ

CARATTERISTICHE AZIONAMENTI PRINCIPALI

MAIN DRIVE CHARACTERISTICS / CARACTÉRISTIQUES ACTIONNEMENTS PRINCIPAUX / HAUPTBEDIENUNGSEIGENSCHAFTEN /
ХАРАКТЕРИСТИКА ГЛАВНЫХ ПРИВОДОВ



VELOCITÀ / VITESSE / SPEED / GESCHWINDIGKEIT / СКОРОСТЬ
REAZIONI / RÉACTIONS / REACTIONS / REAKTIONEN / РЕАКЦИИ



TRIFASE	380V	00 Hz	6 kW
MONOFASE	220V	00 Hz	3 / 6 kW



m/l'	4,50	18,00	36,00
kg	1.500	1.500	0.600
kW			

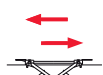

m/l'	9,00*	15,50	00,00
kW		* [con inverter]	

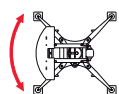

m/l'	0,00	0,60	1 g / min
kW		* [con inverter]	

R = 1,8 m

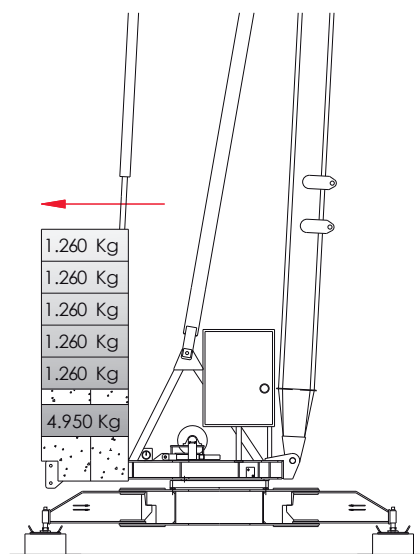

F = 11.000 daN

21 m

0,800 Kg

m ▶	12,46	15,00	17,00	19,00	21,00
Kg	1.500	1.197	1.030	0.902	0.800

24 m

0,600 Kg

m ▶	11,30	14,00	16,00	18,00	20,00	22,00	24,00
Kg	1.500	1.153	0.980	0.850	0.748	0.667	0.600

I

R [m]

RAGGIO DI ROTAZIONE

GB

SPIN BEAM

F

RAYON DEROTATION

D

UMDREHUNGSRADIUS

RUS

РАДИУС ВРАЩЕНИЯ

F [daN]

SFORZI

STRESSES

EFFORTS

KRÄFTE

УСИЛИЯ

SOLUZIONE DI TRAINO

TRACK LOAD PLAN / PLAN DE CHARGEMENT / SCHLEPPLÖSUNG / ВАРИАНТ БУКСИРОВКИ

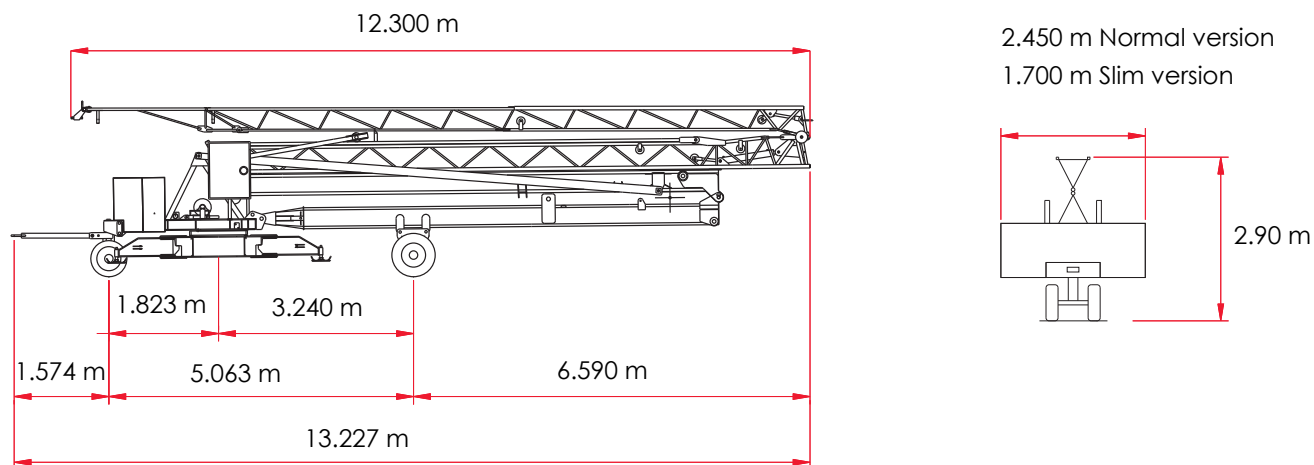
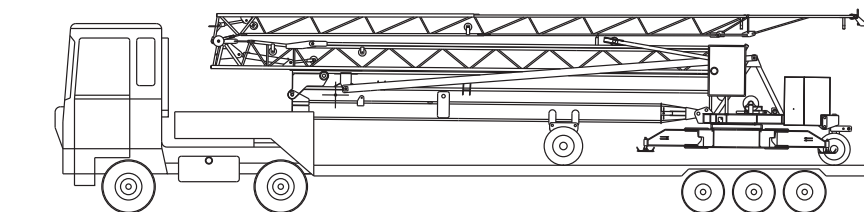
**I**PESO DELLA GRU SENZA
ASSALI: 6.120 Kg**GB**DEAD WEIGHT WITHOUT
TRANSPORT AXALES
6.120 Kg**F**POIDS DE LA GRUE SANS
ESSIEUX 6.120 Kg**D**GEWICHT DES KRANS
OHNE ACHSEN 6.120 Kg**RUS**ВЕС КРАНА БЕЗ
МОСТОВ, 6.120 KgPESO ZAVORRA ROTANTE:
12.570 KgROTATING BALLAST
WEIGHT 12.570 KgPOIDS LEST PIVOTANT
12.570 KgGEWICHT DES DREHBAL-
LASTS 12.570 KgВЕС ВРАЩАЮЩЕГОСЯ
БАЛЛАСТА, 12.570 Kg

DISTRIBUTORE / DEALER / DISTRIBUTEUR / VERTEILER / ДИЛЕР

**CARLO RAIMONDI S.p.A.**CORSO GARIBALDI n° 253
20025 LEGNANO [MI] - ITALY@ www.raimondigru.it

0039.0331.548061



0039.0331.450400



0039.0331.548061



0039.0331.548061.258

DIN EN ISO 9001:2000
Zertifikat n° 15 100 85248